

#10-32 SHUTTLE VALVES



Shuttle Valves

There are three models of shuttle valves offered by Clippard. These valves feature a shuttle that allows flow from one inlet to the outlet while blocking the other inlet. They may be mounted directly to valves and cylinders or inline using the hose barbs on the MSV models.

Poppet type shuttle (double check) valve.
Brass body, and poppet, Buna-N seal



Medium: Air, Water or Oil

Input Pressure: 250 psig/17.5 bar max.

Air Flow: 5.0 SCFM @ 50 psig; 9.5 SCFM @ 100 psig; 230 l/min @ 6 bar

Mounting: Direct or inline

Operation: Flow from "A" to "C" or "B" to "C"

Pressure to Shift: 1/2 psig approx.

Exhaust: Through port where pressure was last applied

Note: Shuttle valves should not be used as a pressure selector



Part No.
MSV-1
MSV-1-M5

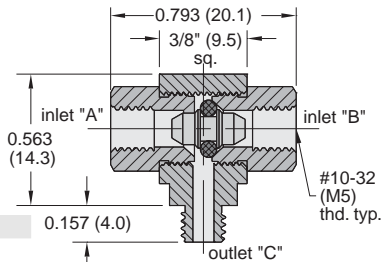

Part No.
MSV-1M22

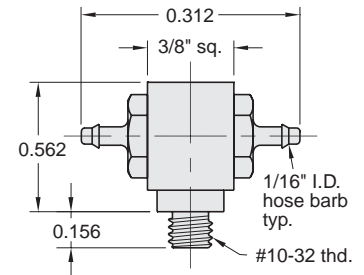

Part No.
MSV-1M44

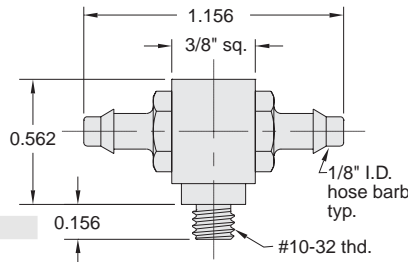

Part No.
MSV-1FFF

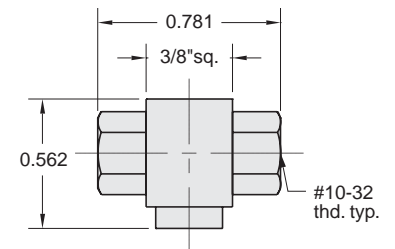

Part No.
MSV-1F22

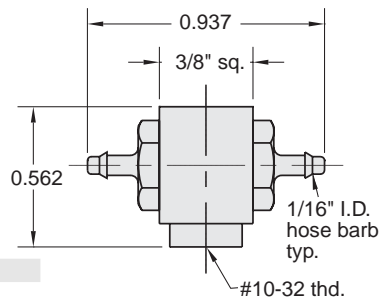

Part No.
MSV-1F44

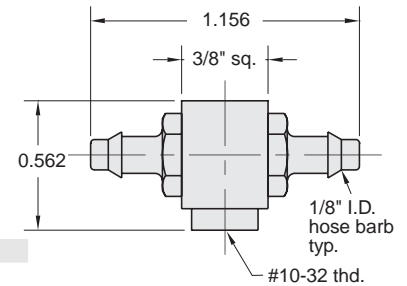

Part No.
MSV-1222

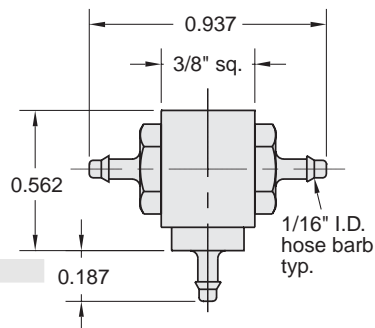

Part No.
MSV-1444

